

# **Convergence, Digitisation and New Technologies: Toward the Next Generation Network**

**By Hu Hanrahan – Centre for Telecommunications Access and  
Services, Wits University**

## **Abstract**

This paper introduces the concept of the Next Generation Network as the vision for convergence between the modern digital Public Switched Telecommunications Network and Internet Protocol Networks. The technological features of the NGN as well as the business models that it facilitates are described. Gateways to the PSTN are described. Migration of the PSTN to the NGN and further evolution of the NGN are outlined. The role of the NGN in providing universal service and universal access is outlined. An example of the use of NGN technologies to create next generation Telecentres is presented.

## **1. Introduction**

The Public Switched Telephone Network (PSTN) is based on digital switching and transmission. User access remains largely analogue via copper wire loops. The PSTN has a significant capacity to provide value-added services such as freephone, split charging, premium charging, virtual private networks and prepaid services. This list of services is limited by market demand rather than the Intelligent Network (IN) technology used [1]. GSM mobile networks, apart from their capability to find mobile users, are similar in nature to the PSTN with value added services such as prepaid calling being added using the same type of IN platform. Current standardisation initiatives such as Parlay [2] aim to enable services which span the public and mobile networks. For example, with a single subscription a user gets call forwarding from a fixed line to a mobile phone with a common voice mail facility. Various charging models are possible: subscriber pays the marginal charge or caller elects to accept cellular rates. New business models become possible. For example, a third party value-added service provider may offer the above service using the connectivity of the fixed and mobile operators.

The Internet, which started out as a best effort network intended to connect computers and computer networks, aspires to be a multi-service network offering both information and real-time services. The Internet relies significantly on telco infrastructure, for example dial-up modem connections, leased lines, frame relay and backbone switching and transmission. Coexistence of the Internet and the public telecommunications network has in the past been based on the Internet's need to use the infrastructure. With Internet technology being used for real time services such as telephony, we enter the era of converged networks.

Convergence is the process of interconnection of traditional switched circuit networks (the PSTN and mobile networks) and packet-switched networks based on the Internet Protocol<sup>1</sup> (IP) for routing. Convergence introduces new requirements. Firstly, the IP networks supporting the Internet never had the stringent quality of service and high availability requirements. All services could tolerate delay and interruptions. When Voice over Internet Protocol (VoIP) is used in a public, tariffed telecommunications service, the need to have 99.999% (5-nines) availability and speech quality close to that in the PSTN fall on a network first conceived as a best-effort network.

---

<sup>1</sup> We distinguish between IP networks and the Internet. An IP network is one in which packets are routed through the network using the Internet Protocol. The Internet is a world-wide set of interconnected networks using the IP routing protocol and providing a characteristic set of services such as e-mail, web browsing and file transfer.

Secondly, VoIP networks can not exist in isolation: interworking with the PSTN is essential and is the focus of intense standardisation activity. Thirdly, the IP-based part of the converged network is capable of providing both real-time services such as telephony, as well as information services. IP networks engineered for quality of service will be capable of providing more secure, available and reliable information and e-commerce service. Subscribers to an IP based network could be presented with a bouquet of real time and information services by their service provider. The service provider could in turn be a traditional telco, a new entrant or a service retailer.

This paper concentrates on the imminent transition in public networks from the traditional Public Switched Telephone Network to the so called Next Generation Network (NGN) [3]. The NGN will be deployed extensively by new entrant telcos as well as incumbent operators. The objective of the latter is to migrate away from the PSTN over time.

The vision of the Next Generation Network (NGN) is captured in the following features:

- Packet network transport with adequate Quality of Service is used for real-time services such as packet telephony and videoconferencing;
- Internet Protocol (IP) is used as the dominant network layer protocol, particularly as presented at the network edge and as seen by the end user (Other protocols such as ATM may be used for backbone transport but will be transparent to the user);
- Voice over IP (VoIP) telephony is seen to be the first service to be implemented in the NGN with other services following over time;
- IP access at the customer premises is made available through a (still to be) standardised gateway;
- Intelligence is distributed across the network (initially supported by signalling interworking rather than a full distributed processing environment);
- The NGN must interwork with Switched Circuit Networks (SCN) via media, trunking and signalling gateways with gateway controllers;
- Efficient offloading of dial-up data traffic from the PSTN will be achieved by access servers closely coupled to end exchanges;
- Because the NGN is basically a packet network and has no intelligence in the routers, service platforms such as IP telephony servers and billing servers will be provided as computing nodes in the IP network;
- VoIP users of the NGN must have access to value added services at least similar to those available in the PSTN (freephone, call forwarding, call waiting). Value-added services may be provided by access to classical IN service platforms in the PSTN or to specialised platforms in the IP network
- Full Operations System Support (OSS) is essential to the effective operation of the NGN;
- Comprehensive accounting facilities in the network supporting flexible billing.

The NGN is seen as evolving in a number of ways:

- Initially the growth of the PSTN will be capped and, over time, voiceband service will migrate to VoIP in the NGN.
- The NGN will evolve to become a multimedia, multi-service network by addition of specialist servers, thus increasing range of services available.
- Networks will be federated to provide services and services will also be federated to provide more advanced services.
- The transport network will evolve toward a full QoS guaranteed network, probably based on label switching.
- Current work indicates that networks and intelligence on customer premises will interwork increasingly with provider networks to deliver advanced services.

- Distributed intelligence will be applied in a consistent way across the network.

The long term goal of incumbent telcos is to migrate progressively to the NGN by phasing out circuit mode transmission and PSTN exchanges. However, the considerable investment in PSTN switches indicates that this process will stretch over a long period. PSTN operators having spare traffic capacity will attempt to increase traffic (and revenue) by allowing third party providers to offer value-added services over their networks. Thus, while the rise of the NGN is likely to be rapid, the decline of the PSTN will be slow.

### **How can the Next Generation Network serve the underserved?**

The next generation network is an approach of new entrant and incumbent telcos to roll out cost effective infrastructure in order to capture market share. The question naturally arises: what is the role of next generation network technology in providing universal telecommunications and information service and universal access to services to underserved communities and in developing countries in general.

The rationale for using an IP based transport network is the reduced cost of switching relative to PSTN exchanges. Also, core network transmission, already inexpensive in relation to switching in the PSTN, offers greater capacities in future due to exploitation of the wide bandwidth available on optic fibre and more efficient methods of carrying packetised traffic. Access is at present the major cost component in providing PSTN services. Access technologies for the Next Generation Network include Asynchronous Digital Subscriber Loops (ADSL) and digital radio loop systems. Fibre based access for low traffic users is a long way in the future. ADSL uses existing copper subscriber loops. While providing greater bandwidth to the end user, ADSL is subject to the operational problems of the current copper loop access. The cost trends of access to the Next Generation Network are not clear and cost is likely to continue to be a factor in providing services to underserved communities. Further research is clearly needed in the access area.

In the next section, we take as an example of the Next Generation Network in the service of underserved communities, namely a proposal for the Next Generation Telecentre being researched at CeTAS [4].

### **Next Generation Telecentres**

The telecentre is a means used in South Africa and other countries to provide access to telecommunications in underserved communities. Typical telecentres already deployed provide a number of telephones, a fax machine and possibly a computer with a dial-up modem [5]. The equipment is installed at a central location in the community, typically in a second-hand ISO container. Connection to the telecommunications network is via phone lines, wireless local loop [6] or GSM radio access channels [7]. At the simplest level, the system is a “phone shop” but may offer additional services for faxing and personal computers with voiceband data connections. Services are constrained by the links between the telecentre and the network, that is either voiceband or GSM channels. Management facilities are provided in the telecentre to enable the network and the telecentre manager to administer payment for services. Pre-paid operation is available in some instances.

The telecentre described above represents a stage in the evolution of service delivery to underserved communities. On one hand, the requirements on the telecentre change, for example from a focus on voiceband communications to providing Internet access to support learning, both formal and informal [8]. On another hand, as the fixed network rollout proceeds members of the community become phone subscribers and the role of the current generation telecentre may

diminish. As the state of development of the community improves, the means of providing services is likely to evolve from a telecentric approach to a normal business relationship between end users and network and service providers for voiceband services.

Looking further into the future public networks will offer broadband multimedia services to business communities in developed areas initially. Underdeveloped communities can benefit from a set of future multimedia services, for example tele-education and telemedicine [9]. The need remains to provide telephony and general Internet access remains to community members both on a subscription and a central basis. Small business must be supported where a potential service is pay per use software to overcome the high recurring costs of basic business software [10,11]. Such services are capable of being supported by the Next Generation Network. What then is the Next Generation Telecentre (NGT)?

The NGT can not be restricted to a single physical location as is the case with current telecentres for three principal reasons. Firstly, services such as telemedicine and tele-education must be delivered at the user's location: the telecentre will therefore be distributed over the area served. Secondly, the same technology is used for telephony in subscriber's premises and made available in a phone shop. Thirdly, the technology used to implement the telecentre is essentially the same as that used for access to the NGN. The NGT is therefore a virtual telecentre, implemented using access network technology for the NGN. Advanced management systems and flexible billing allows users to share the same infrastructure and be billed appropriately.

### **Conclusion**

This paper has introduced the concept of the Next Generation Network, a packet network being introduced alongside the present PSTN. The NGN provides cost-effective infrastructure for new entrant telcos and also allow incumbent telcos to expand telephony-based services as well as providing new ranges of value-added services. The NGN allows new players to enter the telecommunications and information services market. Business models are likely to depart increasingly from the vertically integrated fixed line and mobile networks of today.

In summary:

- The Next Generation Network concept provides a framework for discussion of the technological, regulatory and service aspects of convergence.
- New entrant telcos will implement the NGN immediately and incumbent telcos will migrate to the NGN. The number of interconnection points will increase and a simple approach to interconnect regulation (or deregulation) will be needed.
- The NGN architecture and supporting technologies are not static and will evolve over time.
- The use of Internet protocol as the basic transport mechanism, together with the need for gateways to existing networks require more complex measures of Quality of Service.
- New business models will emerge with many variants of horizontal and vertical alliances requiring a flexible regulatory approach if the growth of the industry is not to be stifled.
- It is believed that, on balance, the Next Generation Network will assist the achievement of universal service and universal access. Also "services" will more readily be expanded beyond basic telephony.
- The question of cost-effective access to the Next Generation Network, particularly in the universal service/universal access context requires further research.

### **References**

1. The International Intelligent Network,

2. Parlay Consortium,
3. G. Lenahan, Next Generation Network,: a practical view of network evolution, Telcordia Technologies
4. Centre for Telecommunications Access and Services, University of the Witwatersrand, Johannesburg.
5. Rashvand, H., Telecentres--Case Study: for a sustainable development in the South African rural communities, International Telecommunications Union: Proceedings of Africa Telekom 98, pages = S5.12.1--S5.12.12, 1998.
6. Opening the airwaves to all. MTN News flash, <http://www.mtn.co.za/news/pr/pr0898-24.html>
7. Siemens Telecommunications, The SIGI Pro successfully uses technology for upliftment of communities in under-developed areas. (Brochure)
8. The ACACIA Initiative, Communities and the Information Society in Africa: program Overview,
9. N. Teckie and F. Ahgdasi, Telemedicine service logic and connectivity implementation in the TINA Service Architecture. Proceedings of SATNAC99, pp 483-487. Available at <http://www.ee.wits.ac.za/~comms/satnac99/index.htm>
10. C. Ip and R.A. Achterberg and H.E.Hanrahan, TINA remote terminal software management service. Proceedings of SATNAC99, pp 461-467. Available at <http://www.ee.wits.ac.za/~comms/satnac99/index.htm>
11. C. Ip. TINA Tele-education Service Design.

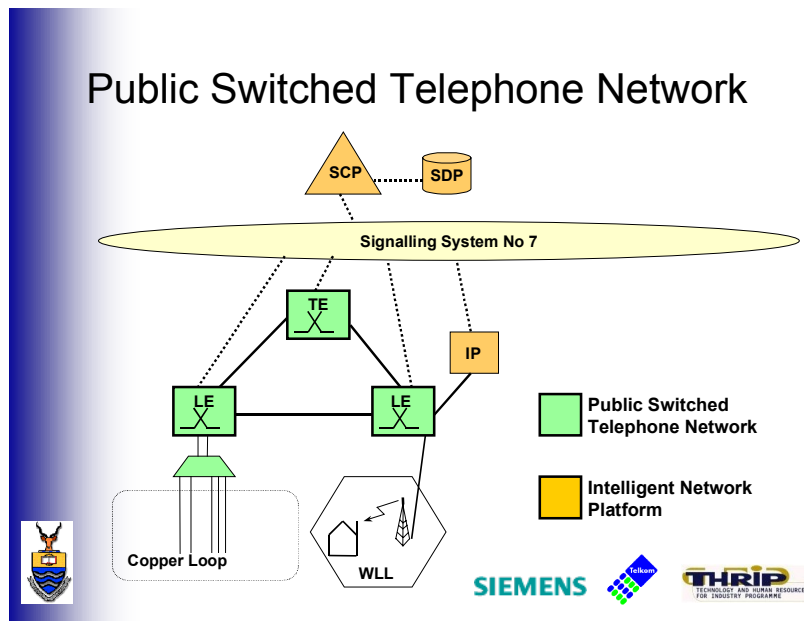

# PSTN & Mobile Networks with IN

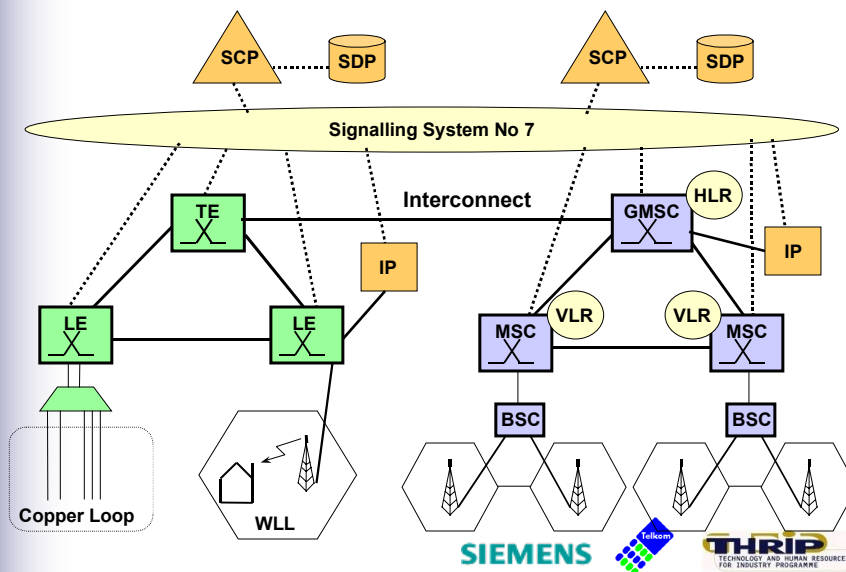

# Next Generation Network

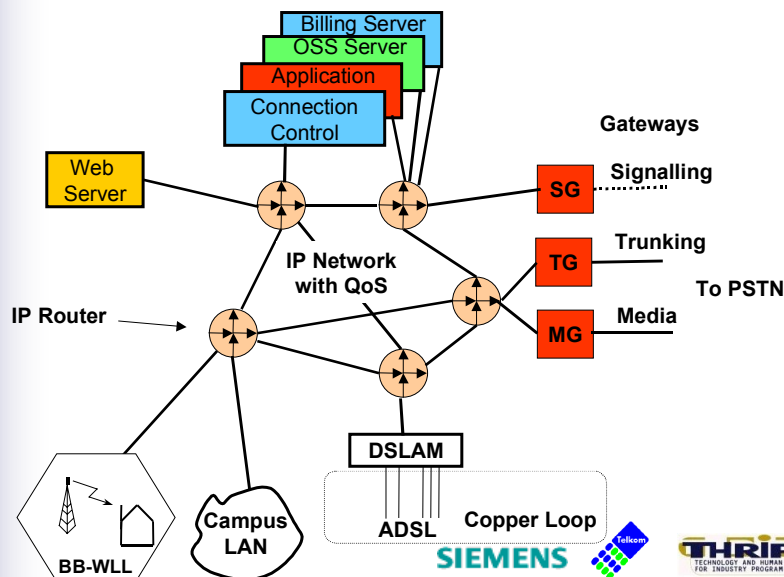

# Converged Network

